

## DC-DC converter HFBC-2DW/O

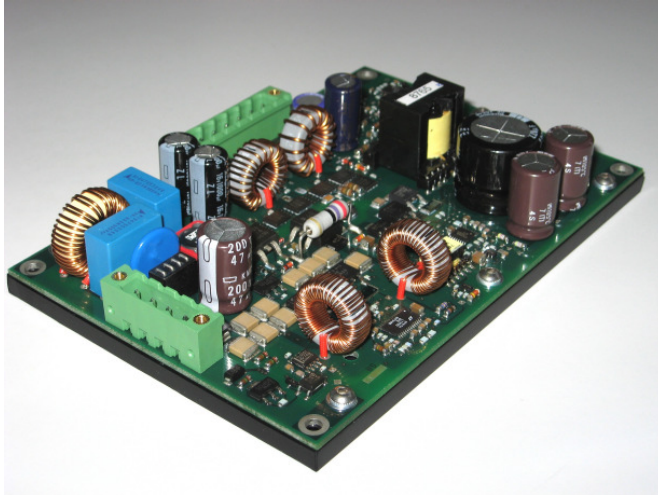

**Output Power 54 Watts**

**Isolated**

**Dual Output**

**Chassis Mounting**

### Features:

- According to Railway Standard EN 50155 and 50121-3-2 (EMC)
- Ultra wide input voltage range
- Extremely low thermal stress due to dissipated power loss over the aluminium baseplate for chassis mounting
- Coated assembly
- Glued parts for better vibration resistance
- Overtemperature shutdown
- Output voltage monitoring (Power Good)
- Enable control input
- Fixed switching frequency 130 kHz
- Active reverse polarity protection
- Short circuit protection
- Zero load operation
- Hold-up time > 10ms (Class S2)
- Active inrush current limiting

# Order Numbers and Specific Characteristics

Other type on request.

										Derating			
$V_{in}$ nom (V)	$V_{out1}$ nom (V)	$V_{out2}$ nom (V)	$I_{out1}$ nom (A)	$I_{out2}$ nom (A)	$P_{out}$ max (W)	$\eta$ typ (%)	$I_{in}$ max (A)	Pro- tector	Type	Order Number	$P_d$ (W)	$T_d$ (°C)	DF (W/K)
$V_{in \text{ operating}} = 16,8 \text{ to } 138 \text{ V}$ , $V_{in \text{ range}} = 14,4 \text{ to } 154 \text{ V}$ <sup>1)</sup>													
24	12	5 <sup>2)</sup>	2	6	54	81	4,6	Internal 5AT	HFBC-2DW/O	01 42 01 0001 4	54	70	1,66 <sup>3)</sup>
36						82							
48						83							
72						84							
110						85							

**Diagram 1: Output Power  $P_{out}$  (W) / Ambient Temperature  $T_{amb}$  (°C)**

Typical characteristic in case of  $V_{in} = V_{in \text{ nom}}$  and free convection up to +85°C. The power derating is proportional for both outputs.

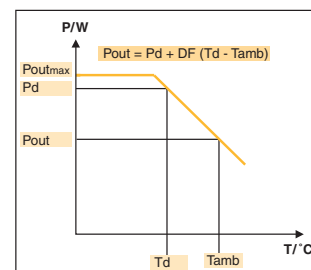

$T_d$  = Reference Temperature of Derating  
 $P_d$  = Output Power at  $T_d$   
 $DF$  = Derating-Factor

<sup>1)</sup> Converter input **and** critical input according to Railway Standard EN 50155 ( $V_{in \text{ operating}}$ ,  $V_{in \text{ range}}$ ).

<sup>2)</sup>  $V_{out2}$  adjusted to 5,1V.

<sup>3)</sup>  $R_{th}$ =2,2 K/W (thermal resistance between converter and ambient at free convection in vertical position).

# Technical Data

For  $T_{amb}=25^{\circ}\text{C}$ ,  $V_{in\ nom}=24\text{V}$ ,  $I_{out\ nom}$ , unless otherwise specified.

## Input Characteristics

	Symbol	Unit	min	typ	max	Notes
Input voltage	$V_{in}$					
Nominal input voltage	$V_{in\ nom}$	V				1)
Input voltage range						
– Min. Input voltage	$V_{in\ min\ (range)}$	V	1)			
– Max. Input voltage	$V_{in\ max\ (range)}$	V			1)	
Threshold						
– Voltage on threshold	$V_{in\ on}$	V		16,7	16,8	
– Voltage off threshold	$V_{in\ off}$	V			14,4	Switches off at $V_{in}$ 14,4...16V after ca. 1s
Input current	$I_{in}$					
Inrush current	$I_{inrush}$	A			6,5	$V_{in} = 16,8...138\text{V}$ , measured after 1ms
Max. input current	$I_{in\ max}$	A			1)	
Standby input current	$I_{in\ off}$	mA		5	10	$V_{in} = 16,8...138\text{V}$ , switched off by EN
Short circuit protection						Internal protector 5AT
Remote on/off by EN						Off: EN-open or connected with $V_{in}$ -; On: EN connected with $V_{in}$ +

## Output Characteristics

	Symbol	Unit	min	typ	max	Notes
Output voltage	$V_{out}$					Short circuit protected and zero load operation
Nominal output voltage	$V_{out\ nom}$	V				1)
Accuracy		%		±0,5		No load
Regulation						
– Line regulation		%		±1		
– Static load regulation		%		±1,6		
– Temperature coefficient		%/K		0,016		
– Dynamic load change Voltage deviation Recovery time		mV/A ms	0,5	1	60 2	10% - 100% - 10% $I_{out\ nom}$
Rising characteristics						Resistive load
– Rise time		ms		150	250	
– Overshoot		%		0	1	
Spikes and noise ( $V_{out}$ 1/2)		mVpp		80/50		20 MHz bandwidth
Ripple ( $V_{out}$ 1/2)		mVpp		35/25		20 MHz bandwidth
Overvoltage protection		V		1,2 $V_{out}$		The converter switches off. For restart switch off and on the converter. External supply at $V_{out}$ is not permissible.
Hold up time		ms	10			Class S2 according EN50155
Nominal output current	$I_{out\ nom}$	A				1)
Overcurrent protection -Threshold -short circuit current			1,1 $I_{out\ nom}$	1,1 $I_{out\ nom}$	1,3 $I_{out\ nom}$	In case of overcurrent the voltage of the overloaded output goes down (constant current).
Output power	$P_{out}$					
Max. output power	$P_{out\ max}$	W			1)	
Derating						1)
Efficiency		%		1)		
Overtemperature shutdown		°C		103		Baseplate temperature. The converter switches off. Restart after cooling down about 5K.

## MTBF

t.b.d.

## Ambient Temperature Range

Operating	-40 up to +70 °C <sup>2)</sup>
Storage/Transport	-40 up to +100 °C

## Isolation

Input/Output	1.500 $V_{eff}$
Input/Case	1.500 $V_{eff}$
Output/Case	500 $V_{eff}$

## EMC

Emission (conducted)	EN 55011 (class B, Quasipeak)
(radiated)	EN 55011 (class A)
Immunity according EN 50121-3-2	
Conducted RF	EN 61000-4-6 (10Vrms, Crit. A)
Electric field	EN 61000-4-3 (10 V/m, Crit. A)
Fast transient (Burst)	EN 61000-4-4 (2kV, Crit. A)
Transient (Surge)	EN 61000-4-5 (42R, 1kV / 2kV, Crit. B)
<b>Mechanical Stress</b>	
Shock	IEC 68-2-27
Continuous Shock	IEC 68-2-29
Vibration	IEC 68-2-6

1) See table "Order numbers and Specific Characteristics" (page 2).

2) max 10 minutes + 85°C at full load (baseplate temperature must not exceed +100°C).

# Special Features

## Enable Input

EN connected with Vin+: converter ON; EN open or connected with Vin-: converter OFF.

Admissible voltage ±154 V  
Source current < 2 mA

## Output Voltage Monitoring (Power good)

Operating criteria for "good"-signal (Transistor is conducting): Both output voltages in the range of  $V_{out\ nom} -5\%$ .

Output PG open collector transistor (n-p-n).  
Admissible current 5 mA  
Admissible voltage +24 V  
Saturation voltage < 1,2 V

# Additional Technical Data

## Drawing (all dimensions in mm)

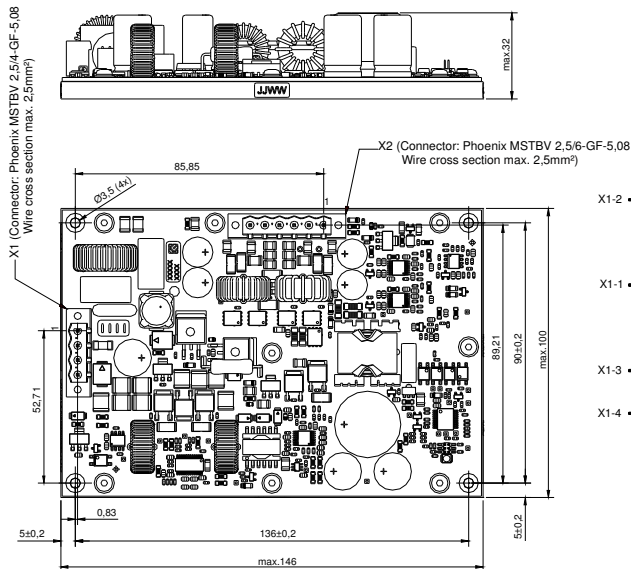

## Block Diagram

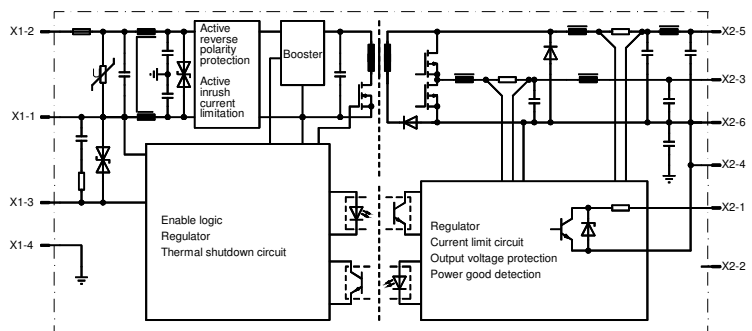

## Installation Instructions

The converters have to be installed according to the guidelines currently in force, like other open electronic component assemblies. Attention must be paid to sufficient ventilation, carry off heat, fastening and protection against accidental contact. The mounting surface must be flat and able to remove the thermal energy of the baseplate (baseplate temperature must not exceed +100°C).

The pin X1-4, Case/PE: (⚡ / ⚙), has to be properly connected in order to assure operation.

In built-in condition our devices may show different EMC properties. Measures of improvement on request.

The converter is equipped with a soldered-in time-lag fuse corresponding to IEC 60127-2 for input protection. For rating of fuse refer to list on Page 2. Pay attention on sufficient current in case of short circuit !

## Pin Allocation

Pin		
X1-1	V <sub>in</sub> -	- Input Voltage
X1-2	V <sub>in</sub> +	+ Input Voltage
X1-3	EN	Enable
X1-4	PE	Case
X2-1	PG+	Output Power good
X2-2	n.c.	Reserved
X2-3	V <sub>out</sub> 2+	+Output Voltage +5V
X2-4	0V	-Output Voltage
X2-5	V <sub>out</sub> 1+	+Output Voltage +12V
X2-6	0V	-Output Voltage

## Packaging

Chassis mounting

## Class of protection

Class I EN 60950

## Degree of protection

IP 00

## Pollution degree

2 EN 60950

## Weight

ca. 350g